

LTC 9449 Series Unity® Dome



Security Systems

EN | Instruction Manual
Prepackaged
Camera Line

BOSCH

Important Safeguards

1. **Read, Follow, and Retain Instructions** - All safety and operating instructions should be read and followed before operating the unit. Retain instructions for future reference.
2. **Heed Warnings** - Adhere to all warnings on the unit and in the operating instructions.
3. **Attachments** - Attachments not recommended by the product manufacturer should not be used, as they may cause hazards.
4. **Installation Cautions** - Do not place this unit on an unstable stand, tripod, bracket, or mount. The unit may fall, causing serious injury to a person and serious damage to the unit. Use only manufacturer-recommended accessories, or those sold with the product. Mount the unit per the manufacturer's instructions. Appliance and cart combination should be moved with care. Quick stops, excessive force, or uneven surfaces may cause the appliance and cart combination to overturn.
5. **Cleaning** - Unplug the unit from the outlet before cleaning. Follow any instructions provided with the unit. Generally, using a damp cloth for cleaning is sufficient. Do not use liquid cleaners or aerosol cleaners.
6. **Servicing** - Do not attempt to service this unit yourself. Opening or removing covers may expose you to dangerous voltage or other hazards. Refer all servicing to qualified service personnel.
7. **Damage Requiring Service** - Unplug the unit from the main AC power source and refer servicing to qualified service personnel under the following conditions:
 - When the power supply cord or plug is damaged.
 - If liquid has been spilled or an object has fallen into the unit.
 - If the unit has been exposed to water and/or inclement weather (rain, snow, etc.).
 - If the unit does not operate normally, when following the operating instructions. Adjust only those controls specified in the operating instructions. Improper adjustment of other controls may result in damage, and require extensive work by a qualified technician to restore the unit to normal operation.
 - If the unit has been dropped or the cabinet damaged.
 - If the unit exhibits a distinct change in performance, this indicates that service is needed.
8. **Replacement Parts** - When replacement parts are required, the service technician should use replacement parts specified by the manufacturer or that have the same characteristics as the original part. Unauthorized substitutions may result in fire, electrical shock or other hazards.
9. **Safety Check** - Upon completion of servicing or repairs to the unit, ask the service technician to perform safety checks to ensure proper operating condition.
10. **Power Sources** - Operate the unit only from the type of power source indicated on the label. If unsure of the type of power supply to use, contact your dealer or local power company.
 - For units intended to operate from battery power, refer to the operating instructions.
 - For units intended to operate **with External Power Supplies**, use only the recommended approved power supplies.
 - For units intended to operate with a limited power source, this power source must comply with EN60950. Substitutions may damage the unit or cause fire or shock.
 - For units intended to operate at 24VAC, normal input voltage is **24VAC**. Voltage applied to the unit's power input should not exceed 30VAC. User-supplied wiring, from the 24VAC supply to unit, must be in compliance with electrical codes (Class 2 power levels). Do not ground the 24VAC supply at the terminals or at the unit's power supply terminals.
11. **Coax Grounding** - If an outside cable system is connected to the unit, ensure that the cable system is grounded. U.S.A. models only - Section 810 of the National Electrical Code, ANSI/NFPA No.70, provides information regarding proper grounding of the mount and supporting structure, grounding of the coax to a discharge unit, size of grounding conductors, location of discharge unit, connection to grounding electrodes, and requirements for the grounding electrode.
12. **Grounding or Polarization** - This unit may be equipped with a polarized alternating current line plug (a plug with one blade wider than the other). This safety feature allows the plug to fit into the power outlet in only one way. If unable to insert the plug fully into the outlet, try reversing the plug. If the plug still fails to fit, contact an electrician to arrange replacement of the obsolete outlet. Do not defeat the safety purpose of the polarized plug. Alternately, this unit may be equipped with a 3-wire grounding plug (a plug with a third pin, for grounding). This safety feature allows the plug to fit into a grounding power outlet only. If unable to insert the plug into the outlet, contact an electrician to arrange replacement of the obsolete outlet. Do not defeat the safety purpose of the grounding plug.
13. **Lightning** - For added protection during a lightning storm, or when this unit is left unattended and unused for long periods of time, unplug the unit from the wall outlet and disconnect the cable system. This will prevent damage to the unit due to lightning and power line surges.

For Indoor Product

1. **Water and Moisture** - Do not use this unit near water - for example, in a wet basement, in an unprotected outdoor installation or in any area classified as a wet location.
2. **Object and Liquid Entry** - Never push objects of any kind into this unit through openings, as they may touch dangerous voltage points or short out parts that could result in a fire or electrical shock. Never spill liquid of any kind on the unit.
3. **Power Cord and Power Cord Protection** - For units intended to operate with 230VAC, 50Hz, the input and output power cord must comply with the latest versions of IEC Publication 227 or IEC Publication 245.
Power supply cords should be routed so they are not likely to be walked on or pinched. Pay particular attention to location of cords and plugs, convenience receptacles, and the point of exit from the appliance.
4. **Overloading** - Do not overload outlets and extension cords; this can result in a risk of fire or electrical shock.

For Outdoor Product

Power Lines - An outdoor system should not be located in the vicinity of overhead power lines, electric lights or power circuits, or where it may contact such power lines or circuits. When installing an outdoor system, extreme care should be taken to keep from touching power lines or circuits, as this contact might be fatal. U.S.A. models only - refer to the National Electrical Code Article 820 regarding installation of CATV systems.

For Rack-mount Product

1. **Ventilation** - This unit should not be placed in a built-in installation or rack, unless proper ventilation is provided, or the manufacturer's instructions have been adhered to. The equipment must not exceed its maximum operating temperature requirements.
2. **Mechanical Loading** - Mounting of the equipment in a rack shall be such that a hazardous condition is not achieved due to uneven mechanical loading.

Safety Precautions



CAUTION

RISK OF ELECTRIC SHOCK. DO NOT OPEN!



CAUTION: TO REDUCE THE RISK OF ELECTRIC SHOCK, DO NOT REMOVE COVER (OR BACK). NO USER SERVICEABLE PARTS INSIDE. REFER SERVICING TO QUALIFIED SERVICE PERSONNEL.



This symbol indicates the presence of uninsulated "dangerous voltage" within the product's enclosure. This may constitute a risk of electric shock.



The user should consult the operating and maintenance (servicing) instructions in the literature accompanying the appliance.



Attention: Installation should be performed by qualified service personnel only in accordance with the National Electrical Code or applicable local codes.



Power Disconnect. Units with or without ON-OFF switches have power supplied to the unit whenever the power cord is inserted into the power source; however, the unit is operational only when the ON-OFF switch is in the ON position. The power cord is the main power disconnect for all units.

FCC & ICES INFORMATION

(U.S.A. and Canadian Models Only)

This device complies with part 15 of the FCC Rules. Operation is subject to the following two conditions:



- (1) This device may not cause harmful interference, and
- (2) This device must accept any interference received, including interference that may cause undesired operation.

NOTE: This equipment has been tested and found to comply with the limits for a Class A digital device, pursuant to Part 15 of the FCC Rules and ICES-003 of Industry Canada. These limits are designed to provide reasonable protection against harmful interference when the equipment is operated in a commercial environment. This equipment generates, uses and radiates radio frequency energy, and if not installed and used in accordance with the instruction manual, may cause harmful interference to radio communications. Operation of this equipment in a residential area is likely to cause harmful interference, in which case the user will be required to correct the interference at his expense.







Intentional or unintentional changes or modifications, not expressly approved by the party responsible for compliance, shall not be made. Any such changes or modifications could void the user's authority to operate the equipment. If necessary, the user should consult the dealer or an experienced radio/television technician for corrective action. The user may find the following booklet, prepared by the Federal Communications Commission, helpful: [How to Identify and Resolve Radio-TV Interference Problems](#). This booklet is available from the U.S. Government Printing Office, Washington, DC 20402, Stock No. 004-000-00345-4.

WARNING: This is a Class A product. In a domestic environment, this product may cause radio interference, in which case, the user may be required to take adequate measures.







Sécurité

	ATTENTION RISQUE D'ÉLECTROCUTION. NE PAS OUVRIR !	
<p>ATTENTION : POUR ÉVITER TOUT RISQUE D'ÉLECTROCUTION, N'ESSAYEZ PAS DE RETIRER LE CAPOT (OU LE PANNEAU ARRIÈRE). CET APPAREIL NE CONTIENT AUCUN COMPOSANT SUSCEPTIBLE D'ÊTRE RÉPARÉ PAR L'UTILISATEUR. CONFIEZ LA RÉPARATION DE L'APPAREIL À DU PERSONNEL QUALIFIÉ.</p>		
	Ce symbole signale que le produit renferme une « tension potentiellement dangereuse » non isolée susceptible de provoquer une électrocution.	
	Ce symbole invite l'utilisateur à consulter les instructions d'utilisation et d'entretien (dépannage) reprises dans la documentation qui accompagne l'appareil.	
	Attention : l'installation doit exclusivement être réalisée par du personnel qualifié, conformément au code national d'électricité américain (NEC) ou au code d'électricité local en vigueur.	
	Coupeure de l'alimentation. Qu'ils soient pourvus ou non d'un commutateur ON/OFF, tous les appareils reçoivent de l'énergie une fois le cordon branché sur la source d'alimentation. Toutefois, l'appareil ne fonctionne réellement que lorsque le commutateur est réglé sur ON. Le débranchement du cordon d'alimentation permet de couper l'alimentation des appareils.	

Sicherheitshinweise

	VORSICHT ELEKTRISCHE SPANNUNG. NICHT ÖFFNEN!	
<p>VORSICHT: UM EINEN ELEKTRISCHEN SCHLAG ZU VERMEIDEN, IST DIE ABDECKUNG (ODER RÜCKSEITE) NICHT ZU ENTFERNEN. ES BEFINDEN SICH KEINE TEILE IN DIESEM BEREICH, DIE VOM BENUTZER GEWARTET WERDEN KÖNNEN. LASSEN SIE WARTUNGSARBEITEN NUR VON QUALIFIZIERTEM WARTUNGSPERSONAL AUSFÜHREN.</p>		
	Das Symbol macht auf nicht isolierte „gefährliche Spannung“ im Gehäuse aufmerksam. Dies kann zu einem elektrischen Schlag führen.	
	Der Benutzer sollte sich ausführlich über Anweisungen für die Bedienung und Instandhaltung (Wartung) in den begleitenden Unterlagen informieren.	
	Achtung! Die Installation sollte nur von qualifiziertem Kundendienstpersonal gemäß jeweils zutreffender Elektrovorschriften ausgeführt werden.	
	Unterbrechung des Netzanschlusses. Geräte mit oder ohne Netzschalter haben Spannung am Gerät anliegen, sobald der Netzstecker in die Steckdose gesteckt wird. Das Gerät ist jedoch nur betriebsbereit, wenn der Netzschalter (EIN/AUS) auf EIN steht. Wenn das Netzkabel aus der Steckdose gezogen wird, ist die Spannungszuführung zum Gerät vollkommen unterbrochen.	

Precauciones de Seguridad

	ATTENZIONE PERICOLO DI SCOSSA ELETTRICA. NON APRIRE.	
<p>PRECAUCIÓN: PARA DISMINUIR EL RIESGO DE DESCARGA ELÉCTRICA, NO RETIRE LA CUBIERTA (NI LA PARTE POSTERIOR). NO EXISTEN PIEZAS DE RECAMBIO EN EL INTERIOR DEL EQUIPO. EL PERSONAL DE SERVICIO CUALIFICADO SE ENCARGA DE REALIZAR LAS REPARACIONES.</p>		
	Este símbolo indica que existen puntos de tensión peligrosos sin aislamiento dentro de la cubierta de la unidad. Estos puntos pueden constituir un riesgo de descarga eléctrica.	
	El usuario debe consultar las instrucciones de funcionamiento y mantenimiento (reparación) en la documentación que se suministra con el aparato.	
	Atención: la instalación la debe realizar únicamente personal cualificado de conformidad con el National Electric Code o las normas aplicables en su país.	
	Desconexión de la alimentación. Las unidades con o sin interruptores de encendido/apagado reciben alimentación eléctrica siempre que el cable de alimentación esté conectado a la fuente de alimentación. Sin embargo, la unidad sólo funciona cuando el interruptor está en la posición de encendido. El cable de alimentación es la principal fuente de desconexión de todas las unidades.	

Veiligheidsmaatregelen

	VOORZICHTIG GEVAAR VOOR ELEKTRISCHE SCHOK. NIET OPENEN!	
<p>VOORZICHTIG: OPEN DE BEHUIZING OF DE ACHTERKANT VAN HET APPARAAT NIET. ZO VERMINDERT U HET RISICO OP ELEKTRISCHE SCHOKKEN. IN HET APPARAAT BEVINDEN ZICH GEEN ONDERDELEN DIE U ZELF KUNT REPAREREN. LAAT SERVICE EN ONDERHOUD UITVOEREN DOOR GEKWALIFICEERD PERSONEEL.</p>		

 Dit symbool geeft aan dat er binnen in het apparaat ongeïsoleerde, gevaarlijke spanning aanwezig is die mogelijk elektrische schokken kan veroorzaken.

 De gebruiker dient de bedienings- en onderhoudsvoorschriften te raadplegen in de documentatie die werd meegeleverd met het apparaat.

 **Attentie:** het apparaat mag alleen door gekwalificeerd personeel worden geïnstalleerd. De installatie dient in overeenstemming met de nationale elektrische richtlijnen of de van toepassing zijnde lokale richtlijnen te worden uitgevoerd.

 **Spanning uitschakelen.** Apparatuur met of zonder aan-uitschakelaar staat onder spanning zolang de stekker is aangesloten op de wandcontactdoos. De apparatuur is uitsluitend in werking als de aan-uitschakelaar aan staat. Het netsnoer is de "hoofdschakelaar" voor alle apparatuur.

Sicurezza

	ATTENZIONE PERICOLO DI SCOSSA ELETTRICA. NON APRIRE.	
<p>ATTENZIONE: PER RIDURRE IL RISCHIO DI SCOSSE ELETTRICHE NON RIMUOVERE LA COPERTURA (O IL PANNELLO POSTERIORE). L'UNITÀ NON CONTIENE COMPONENTI INTERNI RIPARABILI DALL'UTENTE. PER QUALSIASI INTERVENTO, RIVOLGERSI A PERSONALE TECNICO QUALIFICATO.</p>		



 Questo simbolo indica la presenza di "tensione pericolosa" non isolata all'interno del contenitore del prodotto. Ciò comporta un potenziale rischio di scosse elettriche.

 Si consiglia di consultare le istruzioni operative e di manutenzione (interventi tecnici) contenute nella documentazione fornita con il dispositivo.

 **Attentie:** l'installazione deve essere effettuata esclusivamente da personale tecnico qualificato in conformità con il National Electrical Code o con le normative locali vigenti.

 **Scollegamento dell'alimentazione.** Le unità dotate o sprovviste di interruttori ON-OFF vengono alimentate quando si inserisce il cavo nella presa dell'alimentazione. L'unità è tuttavia in funzione solo quando l'interruttore ON-OFF si trova nella posizione ON. Il cavo di alimentazione costituisce il dispositivo di scollegamento dell'alimentazione principale per tutte le unità.

Medidas de Segurança

	UWAGA NIEBEZPIECZENSTWO PORAZENIA PRĄDEM ELEKTRYCZNYM. NIE OTWIERAĆ!	
<p>CUIDADO: PARA REDUZIR O RISCO DE CHOQUE ELÉCTRICO, NÃO RETIRE A TAMPA (OU A PARTE POSTERIOR). NO INTERIOR, NÃO EXISTEM PEÇAS QUE POSSAM SER REPARADAS PELO UTILIZADOR. REMETA A ASSISTÊNCIA PARA OS TÉCNICOS QUALIFICADOS.</p>		

 Este símbolo indica a presença de "tensão perigosa" não isolada dentro da estrutura do produto, o que pode constituir risco de choque eléctrico.

 O utilizador deve consultar as instruções de funcionamento e manutenção (assistência) nos documentos que acompanham o aparelho.

 **Atenção:** a instalação deve ser executada apenas por técnicos qualificados da assistência, de acordo com o código eléctrico nacional ou os códigos locais aplicáveis.

 **Corte de corrente.** As unidades com ou sem interruptores ON-OFF (ligar/desligar) recebem corrente sempre que o fio de alimentação está introduzido na fonte de alimentação; contudo, a unidade apenas está operacional quando o interruptor ON-OFF está na posição ON. O fio de alimentação destina-se a desligar a corrente em todas as unidades.

安全预防措施

	CAUTION RISK OF ELECTRIC SHOCK. DO NOT OPEN	
<p>注意：为避免受到电击，不要拆除机盖（或后盖），用户不得擅自维修里面的部件。有关维修事项，请咨询合格的维修人员。</p>		

 此符号表示产品机壳内存在未绝缘的“危险电压”。这可能导致电击。

 用户应参照设备附带的操作和维护（维修）说明。

 **注意：**安装须由合格的维修人员遵照美国国家电气标准或相关电气规则进行。

 **断开电源。**在电源线插入电源时，配备或未配备 ON/OFF 开关的设备都已通电。但设备只有在 ON/OFF 开关处于 ON 位置时才能工作。对于所有设备，电源线是断开电源的主要方式。

Table of Contents

Important Safeguards	2
FCC Information	4
1 UNPACKING	7
2 SERVICE	7
3 DESCRIPTION	7
4 INSTALLATION	8
4.1 Pipe Mounting	8
4.2 Vertical Surface Mounting	9
4.3 Attaching the Dome to the Mount	9
4.4 Connections for F and N Suffix Models	10
4.5 Dome Removal	10
5 CAMERA SETUP	10
5.1 Camera/Lens Positioning	10
5.2 Lens Varifocal Range Adjustment	10
6 CAMERA & LENS SETTINGS	11
6.1 Backlight Compensation, White Balance, Line Lock, and Phase Settings	11
7 OPERATION	12
8 MAINTENANCE	12
9 SERVICE PARTS	12

1 UNPACKING

This electronic equipment should be unpacked and handled carefully.

- Verify the unit model number.
See DESCRIPTION for detailed specification of model ordered.

If an item appears to have been damaged in shipment, replace it properly in its carton and notify the shipper. If any items are missing, notify your Bosch Security Systems Inc. Sales Representative or Customer Service.

The shipping carton is the safest container in which the unit may be transported. Save it for possible future use.

2 SERVICE

If the unit ever needs repair service, the customer should contact the nearest Bosch Security Systems, Inc. Service Center for authorization to return and shipping instructions.

Service Centers

USA

Phone: 800-366-2283 / 585-340-4162
fax: 800-366-1329
e-mail: cctv.repair@us.bosch.com

CCTV Spare Parts

Phone: 800-894-5215 / 408-957-3065
fax: 408-935-5938
e-mail: BoschCCTVparts@ca.slr.com

Canada

Phone: 514-738-2434
fax: 514-738-8480

Europe, Middle East & Asia Pacific Region

Phone: 44 (0) 1495 274558
fax: 44 (0) 1495 274280
email: rmahelpdesk@solectron.com

For additional information, see

www.boschsecurity.com.

3 DESCRIPTION

Indoor dome, with integrated 1/4inch camera and varifocal lens. See table below for description of various models.

LTC 9449 Series

	MONOCHROME		COLOR	
	MS Series	MH Series	CS Series	CH Series
Camera				
Horizontal Resolution	380TVL	570TVL	330TVL	480TVL
MS Series, MH Series, CS Series, CH Series:				
Voltage Range	12 to 28VAC, 60Hz or 11 to 32VDC			
Power	2Watts			
Lens				
-38 Series	3-8mm, f/1.0 to 360, Auto Iris			
-55 Series	5-50mm, f/1.4 to 185, Auto Iris			
Mechanical				
Mounting Bracket				
-P Series	LTC 9543/00 Pipe Mount (included)			
-W Series	LTC 9540/00 Wall Mount (included)			
Options				
F Suffix	Includes Fiber Optic Transmitter			
N Suffix	Includes Unshielded Twisted Pair Transmitter			
Accessories				
Mounting Hardware				
LTC 9541/01 Pendant Pole (Mast) Mount				
LTC 9542/01 Pendant Corner Mount				
LTC 9230/00 Parapet Mount (requires -P Series model)				
LTC 9316/00P 16 ft Mounting Pole				
Power Supply	RT2440SL: 120VAC 60Hz input; 24VAC 60Hz, 40VA output			

4 INSTALLATION



CAUTION: These units must be properly and securely mounted to a supporting structure capable of sustaining the unit weight. Use care when selecting mounting hardware (not supplied) for installation, the mounting surface and unit's weight should be carefully considered.

4.1 Pipe Mounting

1. The Ceiling Mount (LTC 9543/00) is used to mount the unit to the ceiling.
2. Attach a safety cable to an appropriate point on the ceiling.
3. Feed the cables through the ceiling mount and fasten the mount to the ceiling using 4 fasteners (FIGURE 1). Allow enough cable for the length of the pipe + 1m (3ft). 10mm (3/8in.) bolts/studs are recommended. Bolts should be secured with nuts, washers, and lock washers. Surface fasteners and surface should withstand 270kg (600lb).
4. Each end of the pipe should be threaded to a minimum length of 25.4mm (1in.). Pipe thread standards which may be used are as follows:
 - American National Standard - NPT.
 - British Standard - BSP.
5. If metric pipe thread is used, an adaptor is required at each end of the pipe.
6. Feed the cables through pipe and mounting cap.
7. Make the electrical connection to the supplied mating connector. (See FIGURE 2).

NOTE: On both 24VAC and 12VDC units, either wire can go to either of the specified pins on the mating connector. In multiple camera installations using 24VAC units, connect the wires to the same connectors to ensure proper camera phasing.

- a. Connect the 24VAC or 12VDC power leads to the 24VAC pins and tighten screws.
 - b. Connect the video lead to the BNC connector located on the top of the housing.
8. Connect the mating connector securely to the connector on the connector plate.
 9. Securely tighten the mounting cap onto the pipe to approximately 44N.m (30ft lb).

10. Torque the pipe into ceiling bracket to approximately 44N.m (30ft lbs).
11. If a significant length of pipe is used, support the pipe with braces or guy wires to prevent the swaying motion of the unit from being noticed on the video display.

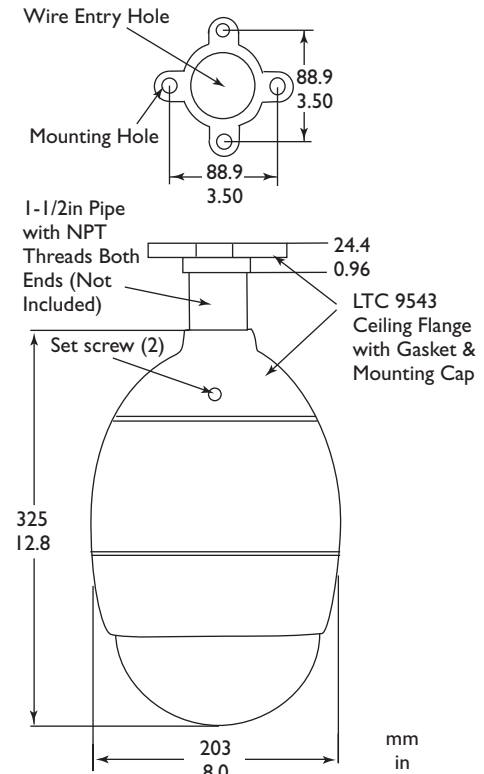

Figure 1: Ceiling/Pipe Mounting

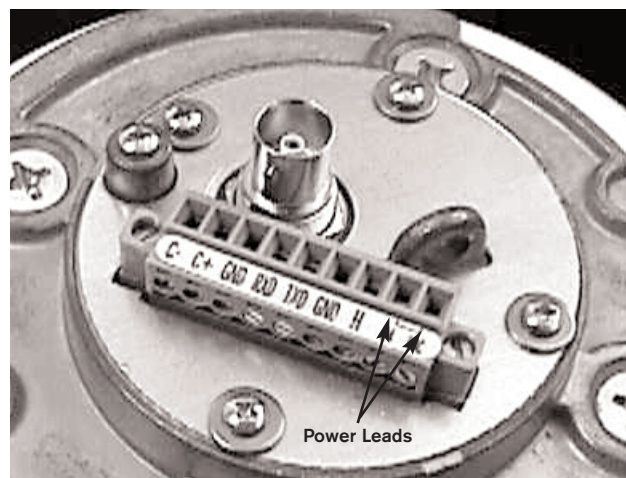

Figure 2: Connector Plate

4.2 Vertical Surface Mounting

1. The Pendant Wall Arm (LTC 9540) is used to mount the pendant to a wall or vertical surface.
2. Feed the power/video cables through the wall mount. Securely mount the bracket in the desired location using 4 fasteners (FIGURE 3). 8mm (5/16in) bolts/studs are recommended. Bolts should be secured with nuts, washers, and lock washers. Fasteners and surface should withstand 270kg (600lb).

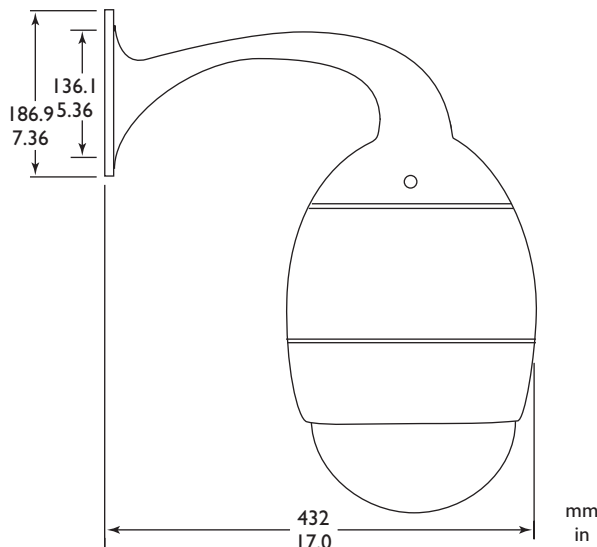
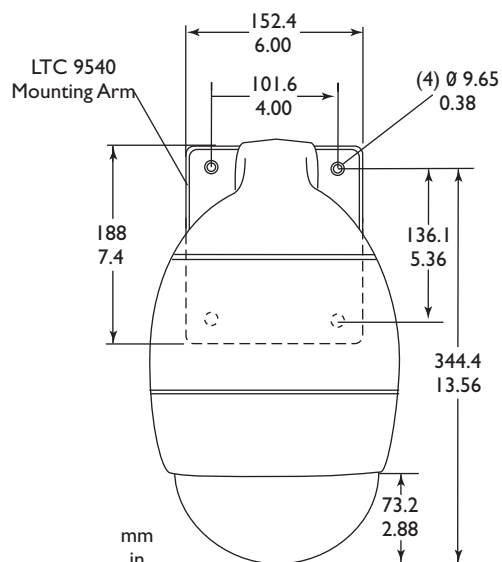

Figure 3: Pendant Arm Mounting



3. Make the electrical connection to the supplied mating connector. (See FIGURE 2).

NOTE: On both 24VAC and 12VDC units, either wire can go to either of the specified pins on the mating connector.

In multiple camera installations using 24VAC units, connect the wires to the same connectors to ensure proper camera phasing.

- a. Connect the 24VAC or 12VDC power leads to the 24VAC pins and tighten the screws.
 - b. Connect the video lead to the BNC connector located on the top of the housing.
4. Connect the mating connector securely to the connector on the connector plate.

4.3 Attaching the Dome to the Mount

1. Once the mount is in place, attach the safety cable to the eyehook on top of the unit.
2. Align the ears on the connector plate with the cutouts in the underside of the mounting arm/ceiling mount.
3. Insert the unit vertically until the bottom face of the mount touches the top face of the unit.
4. Twist 90 degrees in the direction shown in FIGURE 4.
5. Allow the unit to drop into place (the unit should not rotate back to the initial position without lifting slightly).
6. Tighten the 2 set screws.

NOTE: Do not apply significant force when tightening.

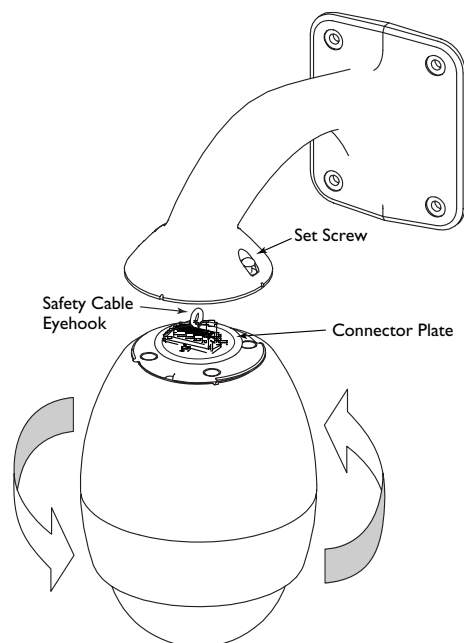

Figure 4: Attaching the Dome

4.4 Connections for F Suffix and N Suffix Models

Connections for models containing fiber optic or twisted pair interfaces are defined in a separate Addendum, provided with those model types.

4.5 Dome Removal

1. Remove the bottom piece of the dome by vertically pulling on the lower half. A safety strap prevents the bottom from dropping.
2. The cameras used in the LTC 9449 Unity Dome Series can be adjusted in a variety of ways; refer to Section 5 for more information.
3. Reattach the dome's bottom half by aligning up its tabs and vertically inserting the unit into the top half until it snaps into place.
4. Adjust the dome bubble to align the viewing slot with the camera.

5 CAMERA SETUP

5.1 Camera/Lens Positioning

The camera mounting brackets allow for camera view adjustments in the X (pan), Y (tilt), and Z (diagonal) planes. Be sure that the alignment indicator on the camera mounting bracket is pointing in an upward direction.

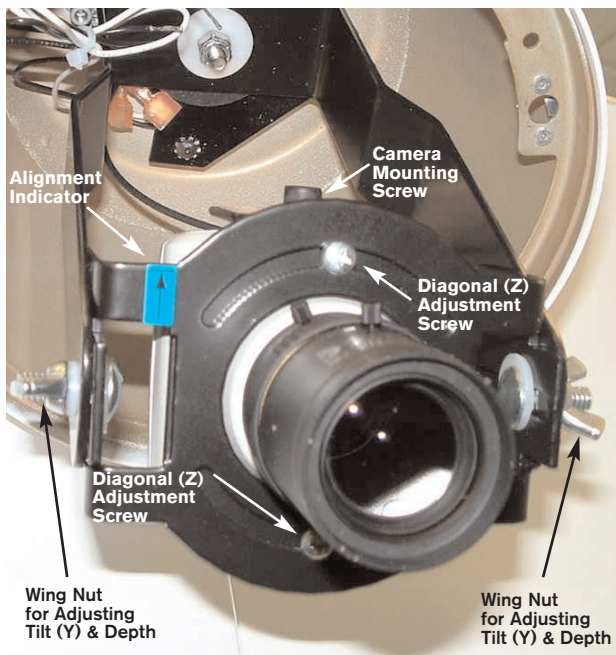

Figure 5: Camera/Lens Positioning

1. X (Pan) Adjustment:
 - a. The camera may be rotated by grasping the slotted bracket, just above the two wing nuts, and twisting it from side to side.
2. Tilt (Y) Adjustment:
 - a. Loosen the wing nut on the side bracket to adjust camera tilt. Pliers may be required to loosen it since the unit is shipped with the wing nut tightened.
 - b. Tilt the camera to the desired position. The camera depth can be adjusted at the same time, by moving the camera along the slots.
 - c. Be sure that the camera alignment is correct. The alignment indicator should be pointing in an upward direction (see FIGURE 4).
4. Diagonal (Z) Adjustment:
 - a. Loosen the two diagonal adjustment screws.
 - b. Grasp the slotted bracket just above the two wing nuts, and twist the bracket along the two curved slots. To prevent pan (X-plane) movement, hold the long bracket below the wing nuts with your other hand.
 - c. Tighten the two diagonal adjustment screws.
5. Be sure that all adjustment nuts are tight after completing camera positioning.

5.2 Lens Varifocal Range Adjustment

These models are provided with either a 3-8mm or 5-50mm varifocal DC auto iris lens.

Adjust focal range to the desired view, as with any varifocal type lens.

6 CAMERA & LENS SETTINGS

6.1 Backlight Compensation, White Balance, Line Lock, and Phase Settings

As received, the unit will be set with the backlight compensation off, the white balance on, and the line lock on. See FIGURE 6a or 6b (depending on the supplied camera) for location of the dip switches and the phase control. See FIGURE 7 for a detailed view. Note that white balance applies to color cameras only.

1. **Dip Switches:** The dipswitches may be changed from their default positions if desired. Remove the lens connector on black cameras to access the dip switches.
2. **Phase Control:** The phase may be adjusted as required by using a small blade screwdriver.

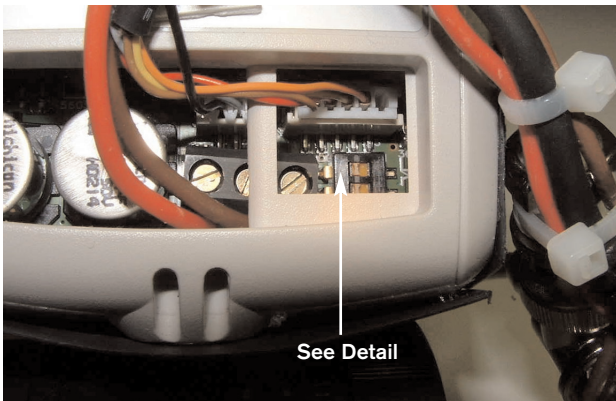

Figure 6a: Location of Camera & Lens Settings; White Camera

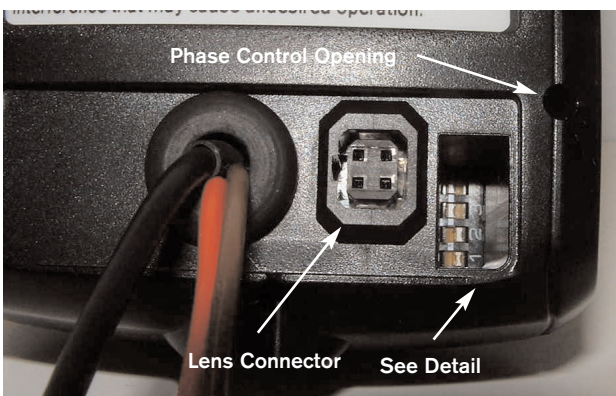

Figure 6b: Location of Camera & Lens Settings; Black Camera

The control functions and settings described below are shown in the same sequence as they appear in FIGURE 7.

Phase Control

V - P H A S E Vertical Phase Adjustment

Default Dipswitch Settings	Color	B&W
4 L L Line Lock	On	On
3 n c Not Used	--	--
2 w b White Balance	On	--
1 b l c Backlight Compensation	Off	Off

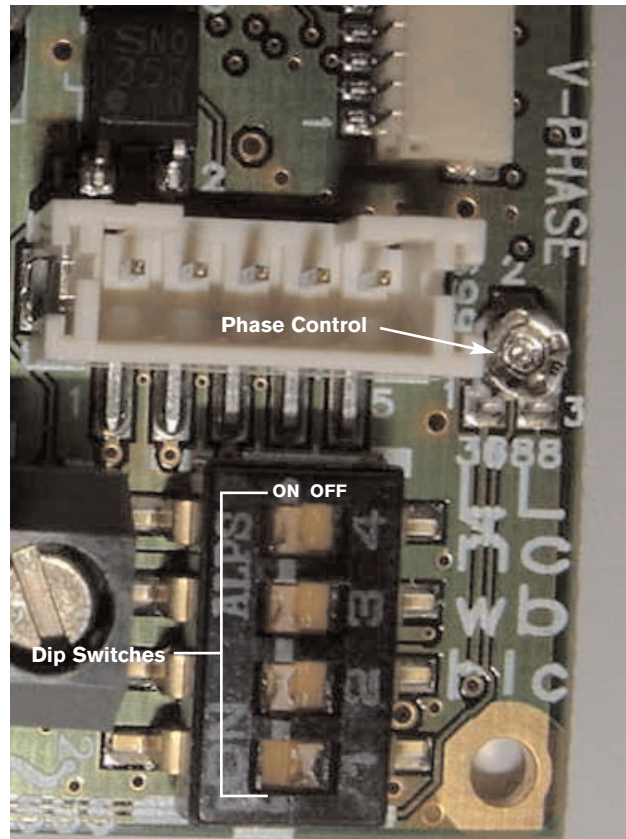

Figure 7: Detail of Adjustments - Default Position

7 OPERATION

These units require no operational adjustments.

8 MAINTENANCE

No special maintenance is required.

Occasionally, dust may accumulate inside the housing and coat the transparent dome/trim ring. Remove any dust in the transparent dome/trim ring interior with clean compressed air, preferably from a spray can. If heavy residue accumulates, flush with water and immediately dry with pressurized air to prevent water spotting.

If internal wiping is necessary, use only microwave-type paper towels, or equivalent soft paper towels. Roll a section into a tightly wound tube, tear tube in half, and wet fuzzy torn end with a solution of isopropyl alcohol diluted with water. While holding the dome with its opening facing down, wipe the interior using a circular motion spiraling in toward the center. Use a new paper towel for each two passes.

To clean the exterior of a transparent dome, use any nonabrasive cleaning that is safe for use on acrylic plastic. Liquid or spray cleaner/wax for use on fine furniture or automobiles, such as Megular's Mirror Glaze Cleaner/Wax 6, is acceptable.

9 SERVICE PARTS

Description	Part No.
Dome Bubble	315 4054 001
B/W Camera	LTC 0135MC
B/W Camera Hi Res	LTC 0155MC
Color Camera	LTC 0235MC
Color Camera Hi Res	LTC 0255MC
3-8mm Varifocal Lens	LTC 3364/32
5-50mm Varifocal Lens (Indoor)	LTC 3374/20
5-50mm Varifocal Lens (Outdoor)	LTC 3374/50

Americas

Bosch Security Systems
130 Perinton Parkway
Fairport, New York, 14450, USA
Phone: +1 (585) 223 4060
+1 800 289 0096
security.sales@us.bosch.com
<http://www.boschsecurity.us>

Europe, Middle East, Africa

Bosch Security Systems B.V.
P.O. Box 80002
5600 JB Eindhoven, The Netherlands
Phone: +31 (0) 40 27 83955
Fax: +31 (0) 40 27 86668
emea.securitysystems@bosch.com
<http://www.boschsecurity.com>

Asia-Pacific

Bosch Security Systems Pte Ltd
38C Jalan Pemimpin
Singapore 577180
Phone: +65 6319 3450
Fax: +65 6319 3499
apr.securitysystems@bosch.com
<http://www.boschsecurity.com>